

**Montageanleitung
DORMA VISUR
Drehtürsystem**

**Installation instruction
DORMA VISUR
pivoting door system**

Montážní dokumentace
DE / EN

Deveraux
GLASSDOORSYSTEMS

Downloaded from www.deveraux.cz

Wichtige Informationen:
Important information:

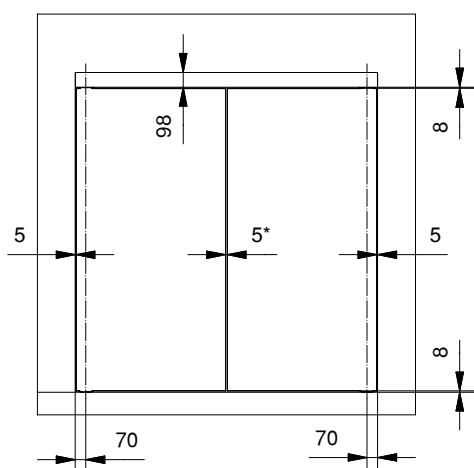

* 5mm Glas/Wand sowie Glas/Glas
 * 5mm glass/wall as well as glass/glass

Vor der Montage Glasflächen mit handelsüblichen Glasreiniger im Bereich der Klemmflächen reinigen.

All glass clamping areas are to be cleaned with standard glass cleaning products prior to installation.



keine Verdünnung verwenden
 do not use thinners



① = Bauteil/Baugruppe
 component

1.; 1.1;...= Montagefolge
 installation sequence

Wichtige Hinweise:
Important points:



Überdrehen der Tür verhindern!
 Stopper verwenden!

Prevent excessive opening of the door,
 Please use a stopper.

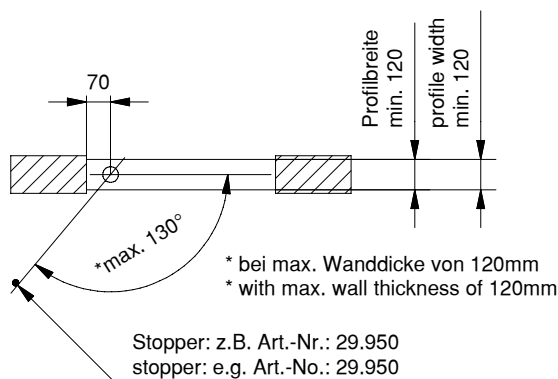

Geeignete, auf den Untergrund abgestimmte Ankersysteme verwenden!

Please use suitable anchorsystems according to foundation!



Das Bodenlager ist nicht gegen eindringendes Wasser geschützt!

The bearing is not protected against water intrusion!



Es ist nur der RTS 85 EN3 90° Feststellung zugelassen.

Only the RTS 85 EN3 90° hold open angle is certified.

Montagewerkzeug:
Installation tool:

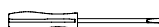
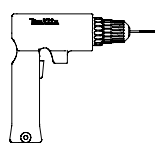

2,5 mm 5 mm 6 mm

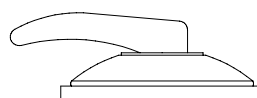

Glassauger / glass suction lifter

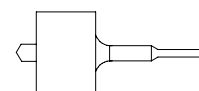

Hammerbohrkrone ø126 /
 hammer core bit ø126

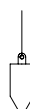
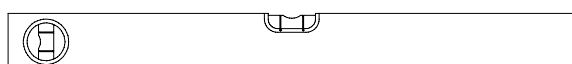

Glasbearbeitung:
Glass preparation:

Glasverwendung: 10/12 mm Einscheibensicherheitsglas
Glass application: 10/12 mm toughened safety glass

DETAIL X

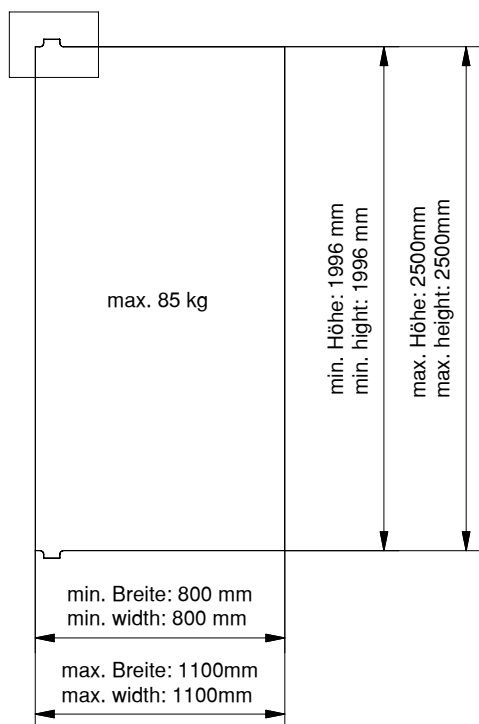

DETAIL X

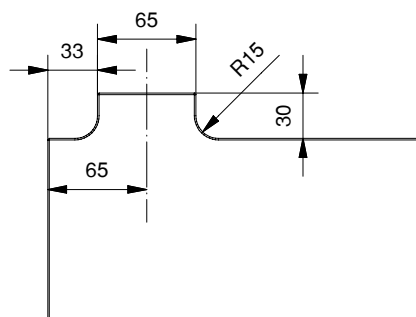

Ausführung der Glaszungen oben und unten gleich!
Top and bottom glass tongues of identical design!

Lieferumfang:
Scope of delivery:

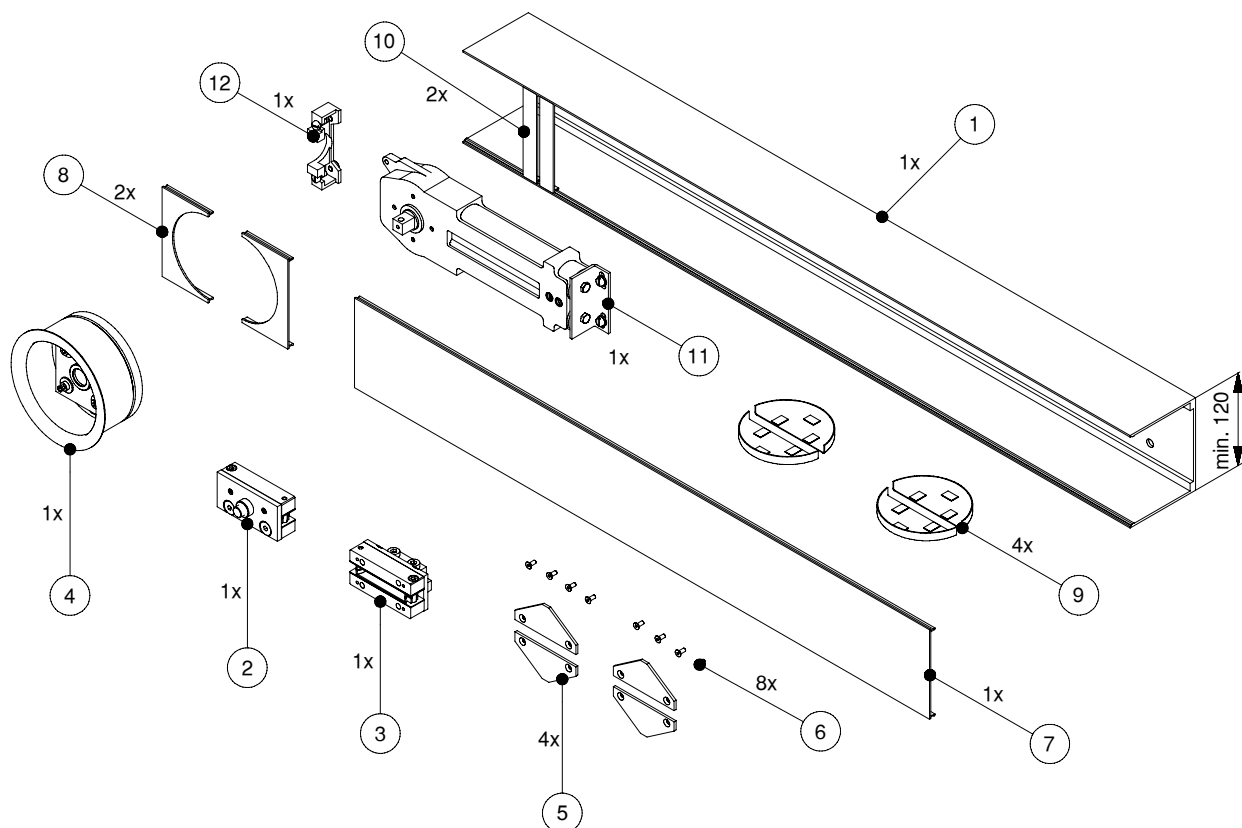

Bei 12mm Glasdicke: Vorbereitung der Beschläge ②, ③

With 12mm glass thickness: Preparation of hinges ②, ③

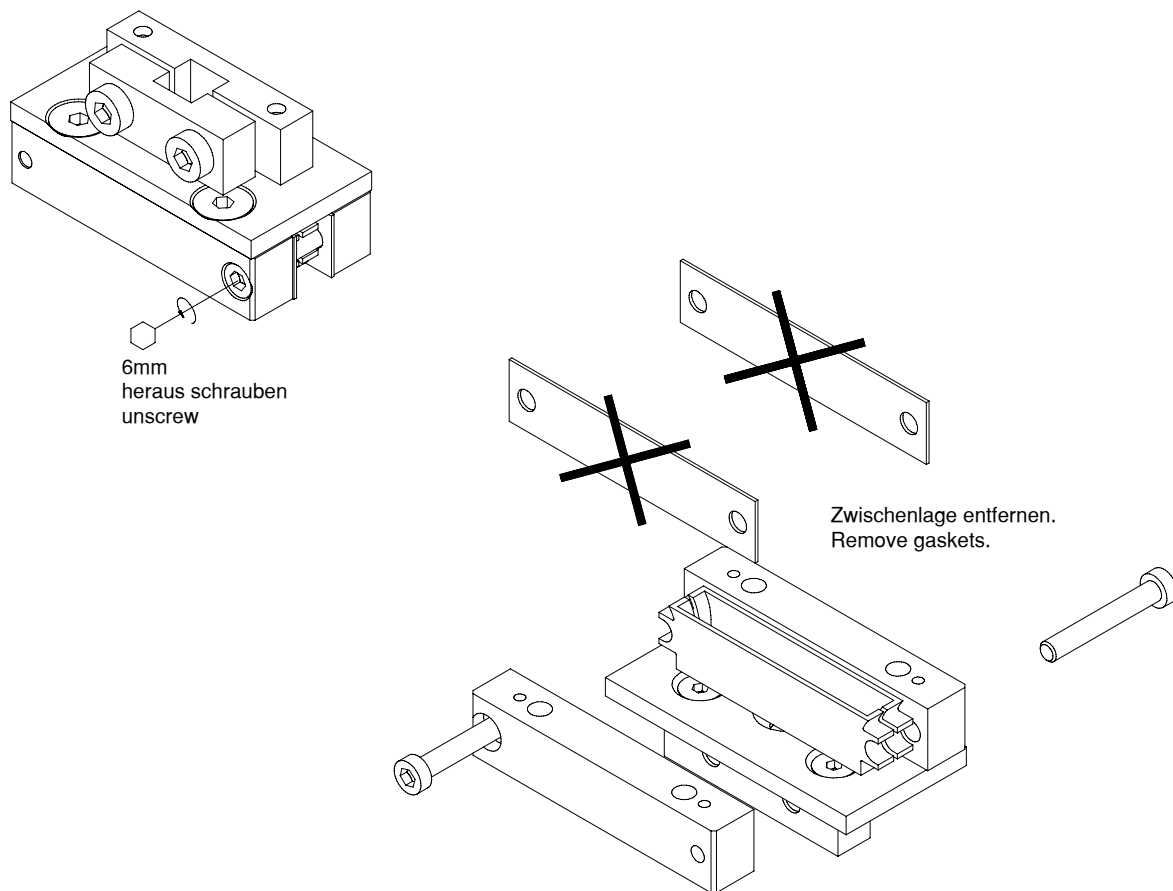

1. Montage des Montagewinkels ⑫ :

1. Assembly of mounting angle ⑫ :



Beim Komplet-Set inkl. Schließerkasten ist der Montagewinkel ⑫ bereits montiert.



In the complete set, incl. transom box, the mounting angle ⑫ is already assembled.

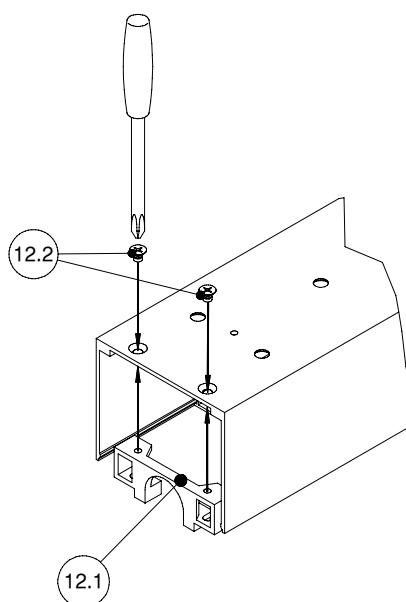

2. Montage des Schließkastens:
2. Installation of the transom box:

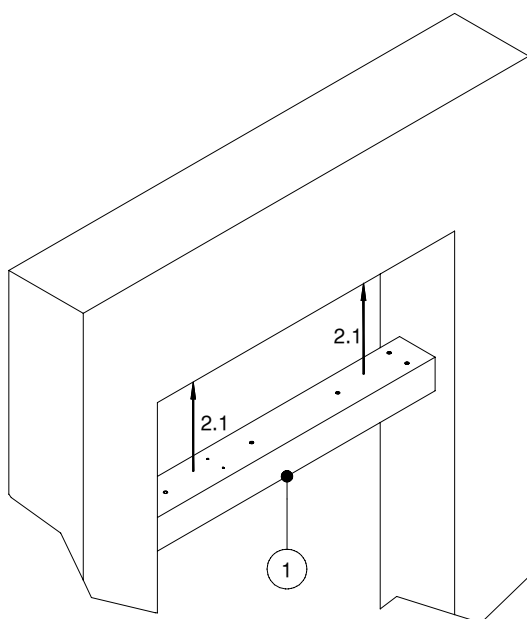

Abstandshalter (10) bei flächenbündiger Deckenanbindung.

Reinforcing spacer bars (10) to be used when transom box is flush with ceiling.

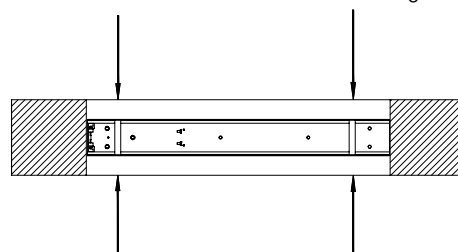

Beispiel / Example

Rohdecke / rough ceiling

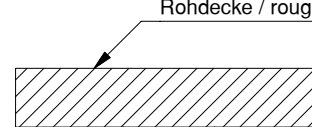

Gipsdecke / plasterboard ceiling



Schrauben und Dübel zur Befestigung, sind nicht im Lieferumfang enthalten! Geeignete, auf den Untergrund abgestimmte Ankersysteme verwenden z.B. Schrauben DIN 912 M8x... oder DIN 7996 6x... Voraussetzung für die Montage des Schließkastens ist eine ausgerichtete und tragfähige Unterkonstruktion bzw. Wand mit einer max. Toleranz von 2mm pro Meter.



Screws and plugs for connection are not part of delivery! Please use suitable anchorsystems according to foundation e.g. screws DIN 912 M8x... or DIN 7996 6x... Pre-condition for the assembly of transom box is an aligned and load-carrying substructure and/or wall with a max. tolerance of 2mm per meter.

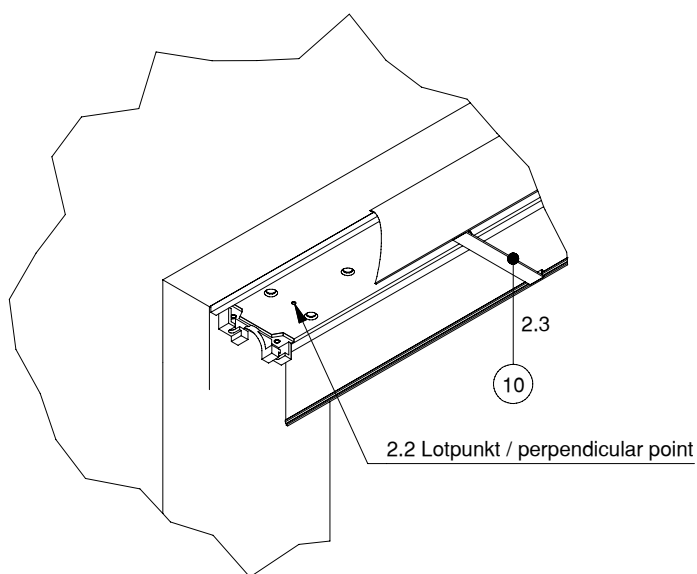

2.2 Drehpunkt aus Schließkasten übernehmen und runterloten.
 2.2 Transfer pivot point from transom box perpendicular to the floor.

2.3 Abstandshalter (10) demontieren.
 2.3 Dismount spacer bars (10).

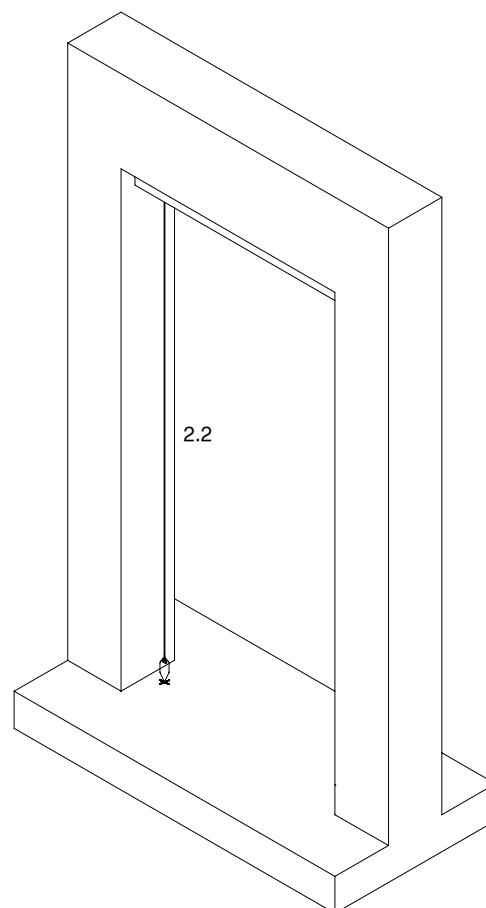

3. Montage Lagertopf im Boden:
3. Installation of casing into floor:

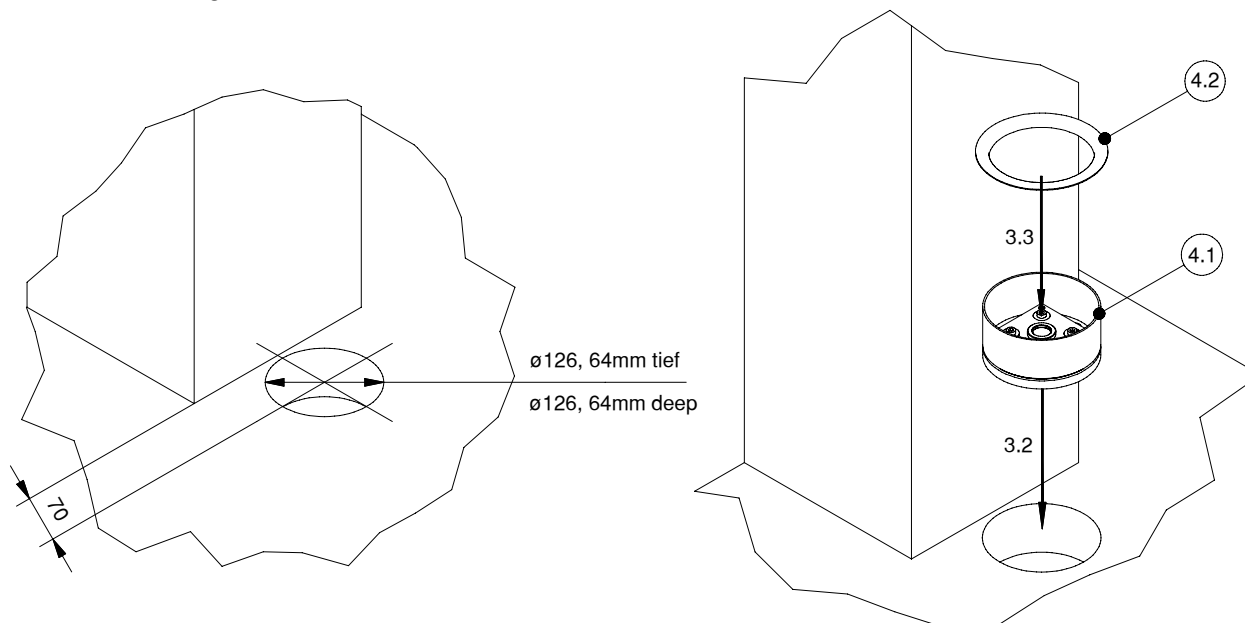

- 3.1 Bohrung $\varnothing 126$ für Lagertopf im Boden einbringen.
 Hammerbohrkrone, Fa. HILTI (TE-Y-BK125/430)
 Art.-Nr.: 00307066 (HILTI)
- 3.1 Setting of bottom hole ($\varnothing 126$) for casing.
 hammer core bit, company HILTI (TE-Y-BK 125/430)
 Art.-No.: 00307066 (HILTI)



Der Untergrund muss tragfähig sein.
 Geeignete, auf den Untergrund abgestimmte Ankersysteme verwenden!

The foundation must be load-carrying.
 Please use suitable achorsystems according to foundation!

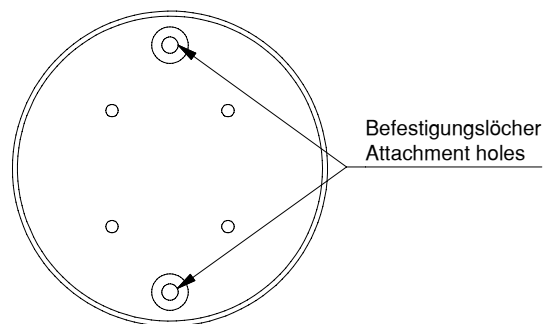

4. Montage des oberen Beschlags:
4. Installation of the top fitting:

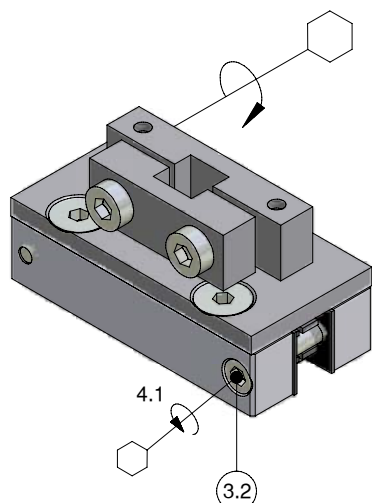

5 mm
 nur lösen / only release

Vormontiert für 10mm Glasdicke!
 Bitte Hinweis auf Seite 4 beachten!



Preassembled for 10mm glass thickness!
 Please pay attention to note on page 4.

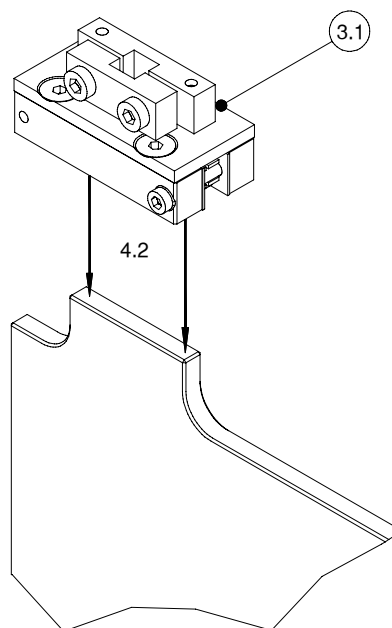

4. Montage des oberen Beschlags:
4. Installation of the top fitting:

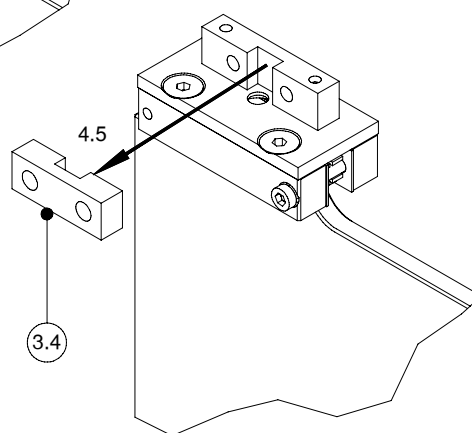
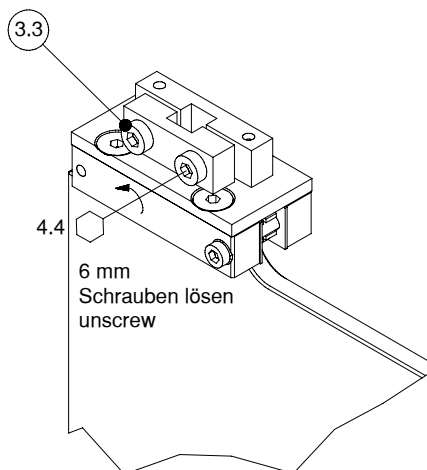
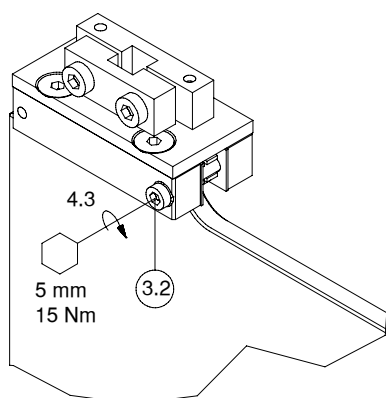

5. Montage des unteren Beschlags:
5. Installation of the bottom fitting:

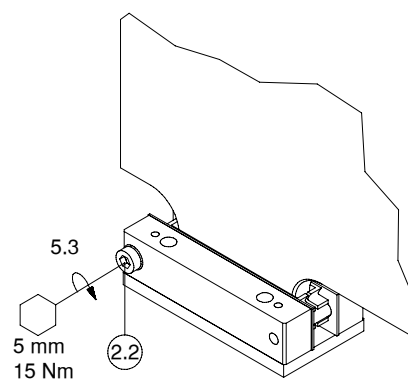
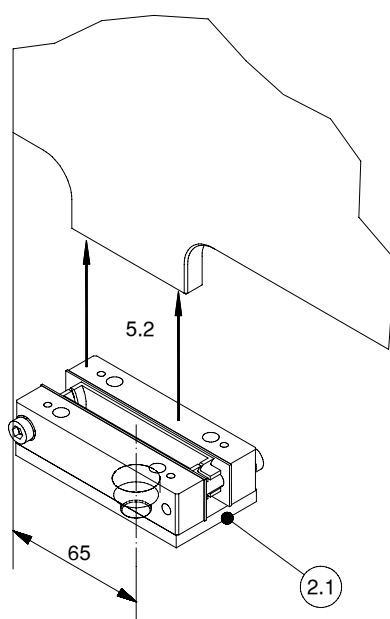
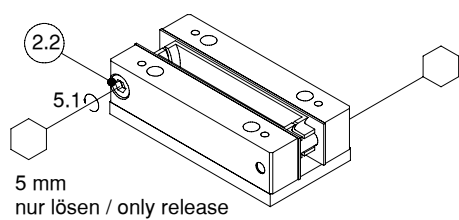

**6. Montage der Drehtür:
6. Installation of pivoting door:**

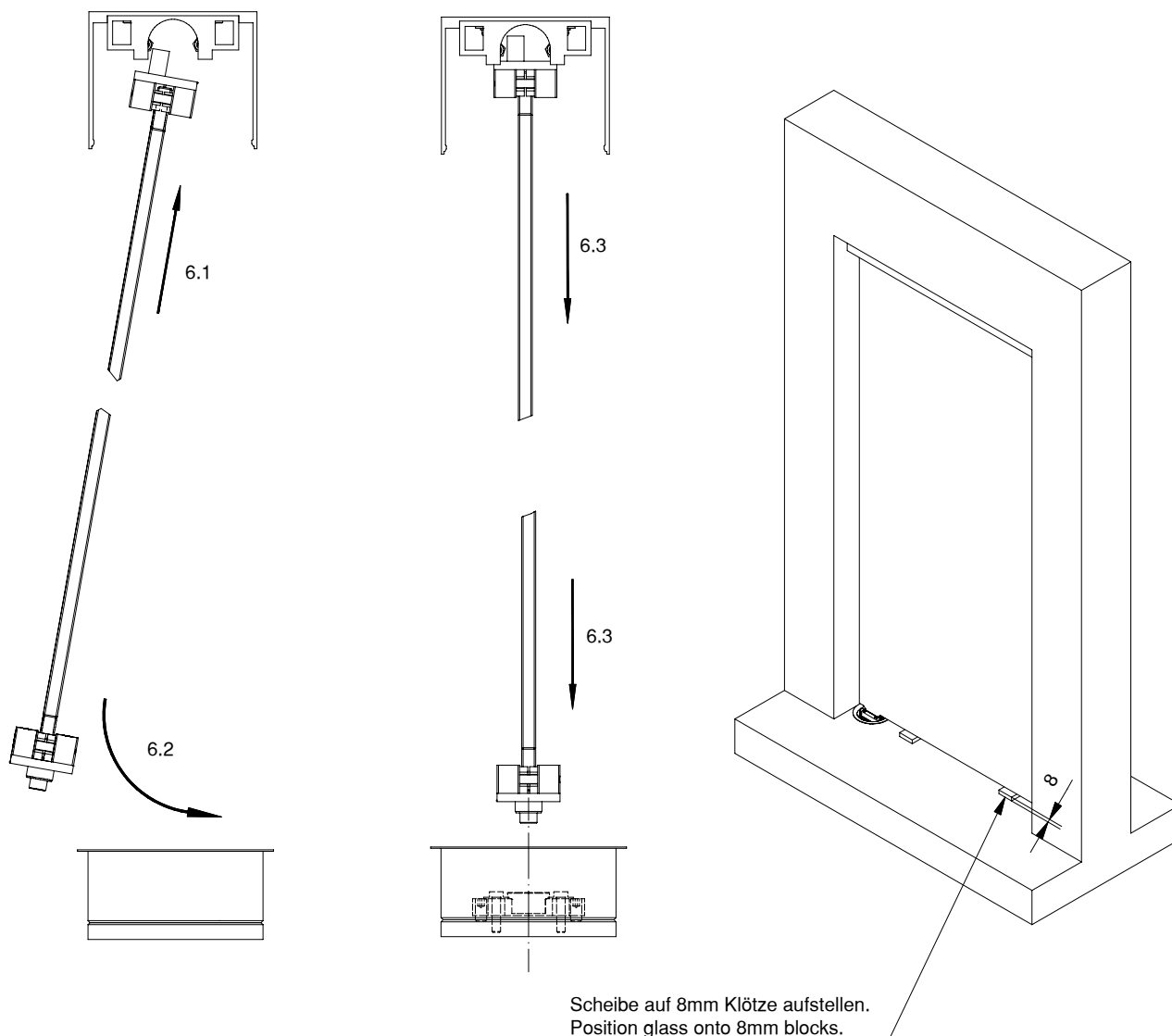

**7. Montage des Rahmentürschließers:
7. Installation of the transom door closer:**

7.1 Tür an RTS-Kasten lehnen.
7.1 Lean the door against the transom box.

7.2 Rahmentürschließer einführen.
7.2 Insert the transom door closer as shown.

Lappen zum Schutz über die Glaskante legen! Bauseits.
Protect glass using cloths! On site.

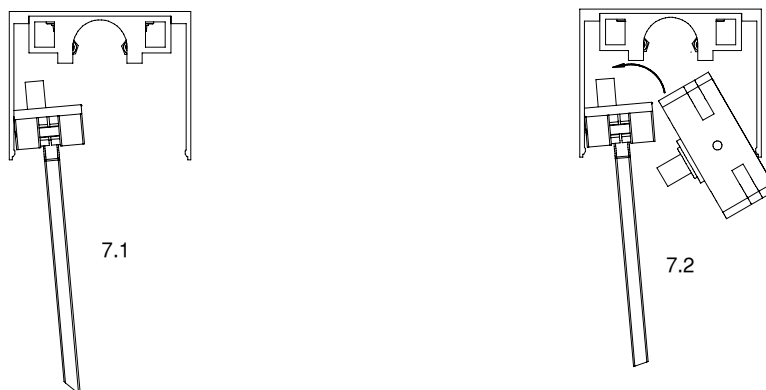

7. Montage des Rahmentürschließers:
7. Installation of the transom door closer:

Sicht: unter den Sturz!
 View: under the lintel!

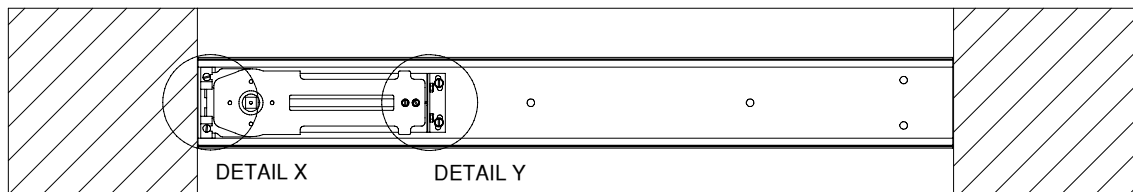

DETAIL X

DETAIL Y

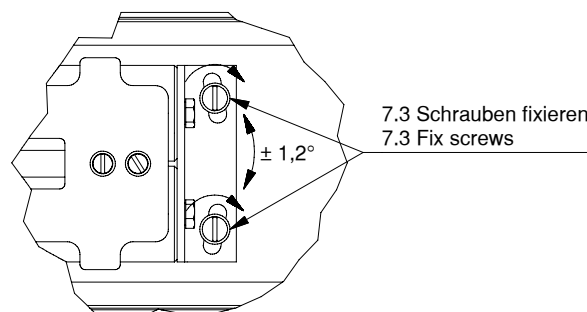
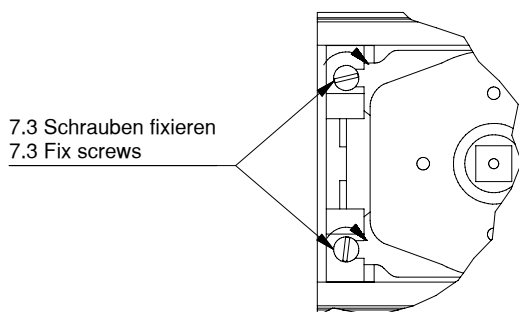

8. Montage der Drehtür:
8. Installation of the pivoting door:

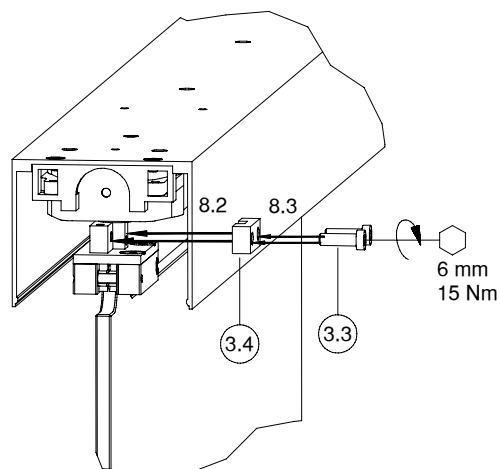
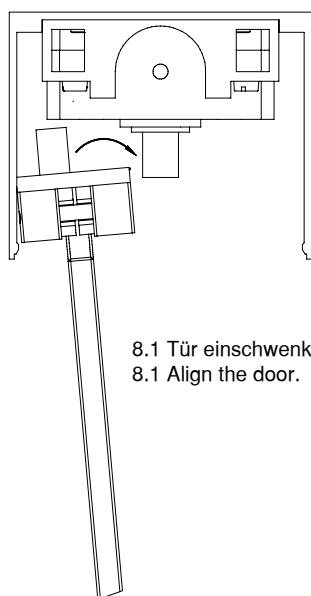

9. Drehtüranlage justieren:
9. Adjustment of pivoting door system:

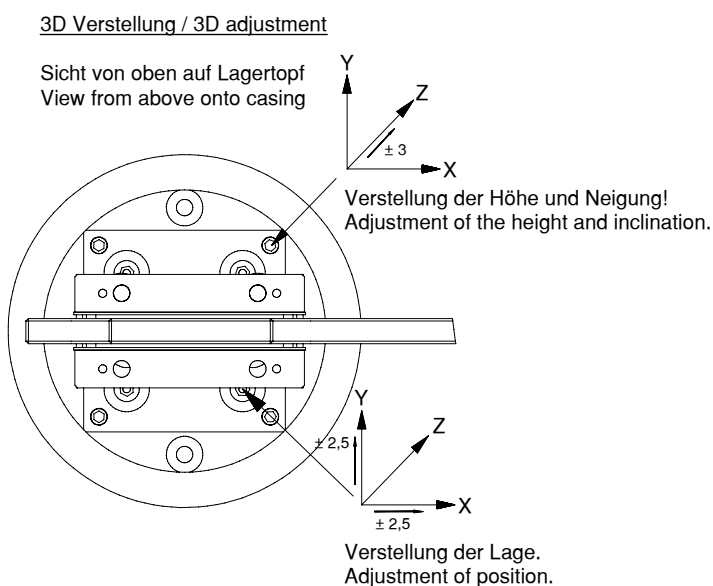
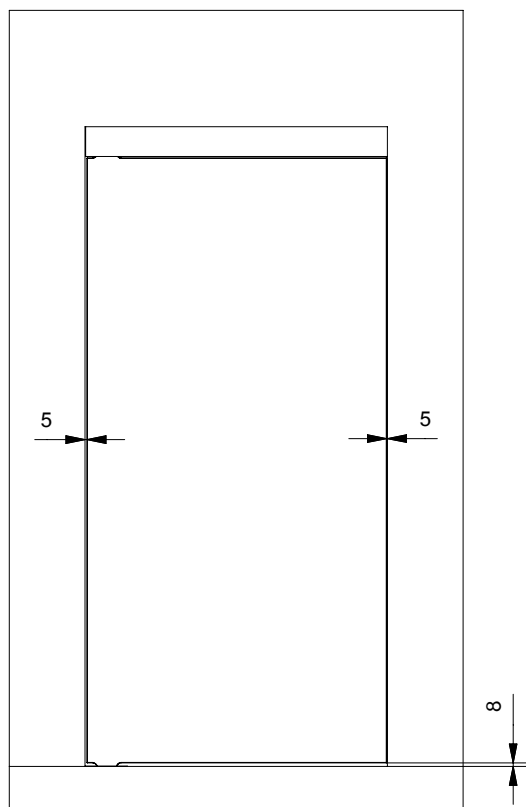

10. Endmontage der Beschläge:
10. Final assembly of the fittings:

DETAIL X

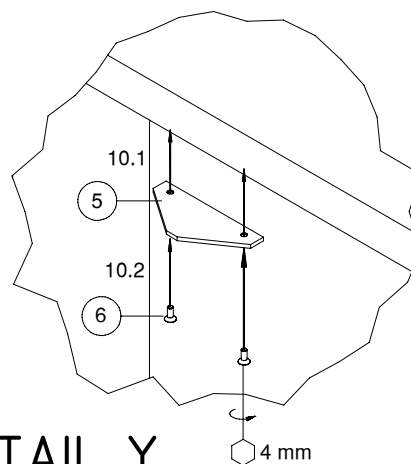
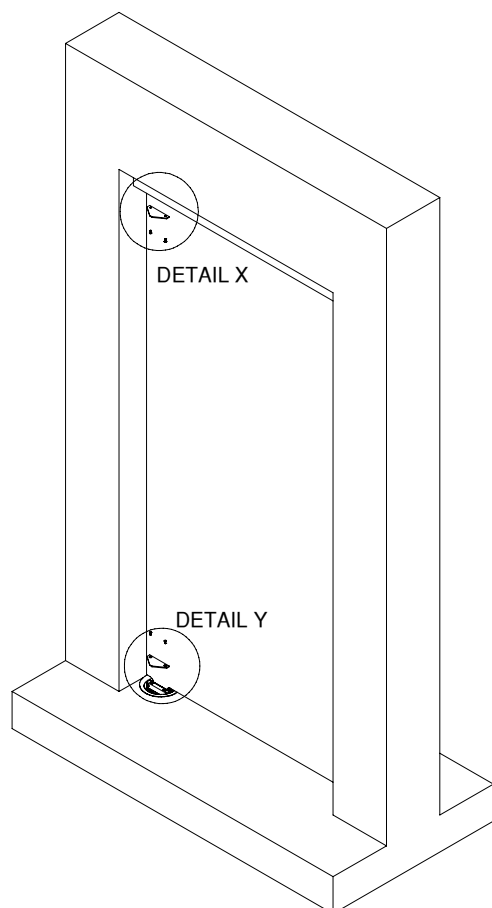

DETAIL Y

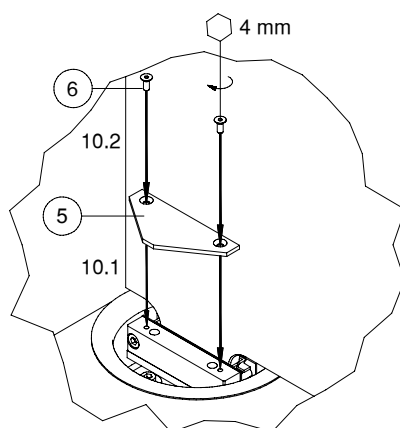

11. Einstellung des Rahmentürschließers:
11. Adjustment of the transom door closer:

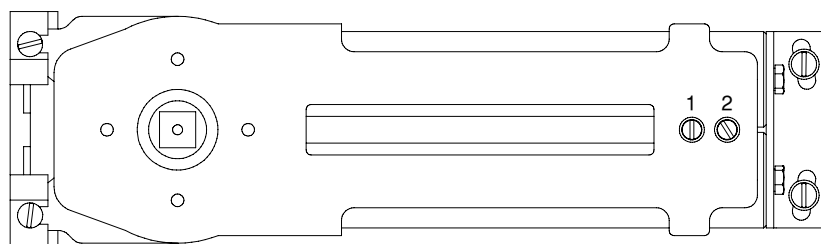

1. Voll kontrolliertes Schließen mit einstellbarer Geschwindigkeit.
Entire control of closing with adjustable speed.
2. Einstellbare Schließdämpfung.
Adjustable closing damping.

12. Endmontage:
12. Final assembly:

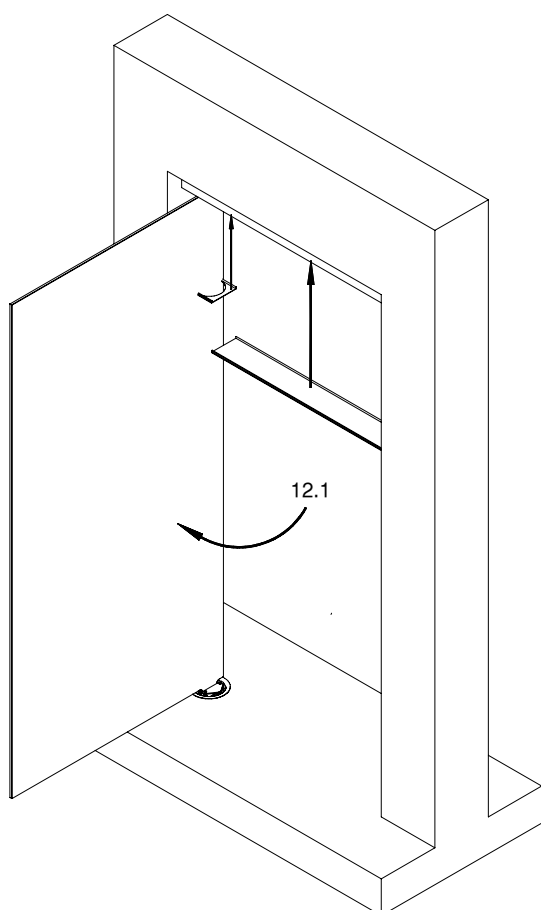

oberer Beschlag
top fitting

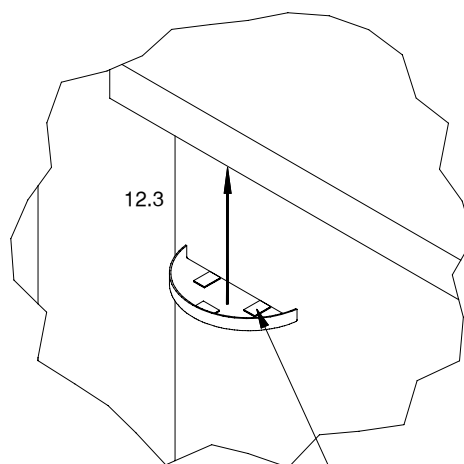

12.2 Folienstreifen abziehen.
12.2 Pull off backing tape.

unterer Beschlag
bottom fitting

