

**Montageanleitung
DORMA
MANET Compact
Schiebetür an Wand/an Glas**

**Installation
DORMA
MANET compact
Sliding door onto wall/onto glass**

**Wichtige Informationen:
Important information:**

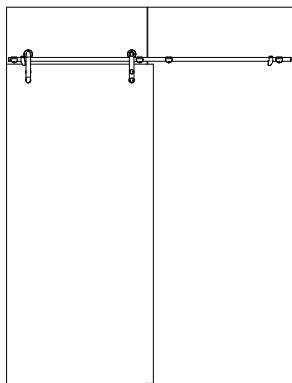

Vor der Montage Glasflächen mit handelsüblichen Glasreiniger im Bereich der Klemmflächen reinigen.

All glass clamping areas are to be cleaned with standard glass cleaning products prior to installation.



keine Verdünnung verwenden
do not use thinners

① = Bauteil/Baugruppe
component

1.; 1.1; ... = Montagefolge
installation sequence

**Glasbearbeitungen:
Glass preparations:**

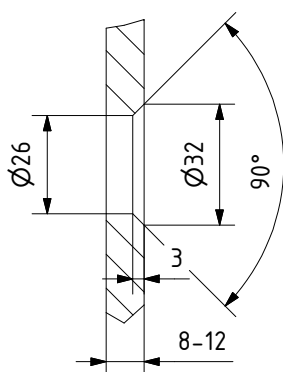

Bohrung für versenkten Punkthalter.
Hole for countersunk single-point fixing.

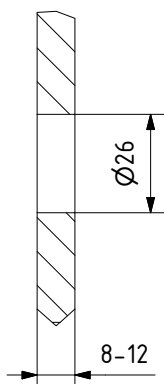

Bohrung für aufliegenden Punkthalter.
Hole for clamping disc single-point fixing.

**Montagewerkzeug:
Installation tool:**

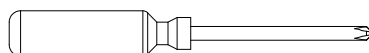
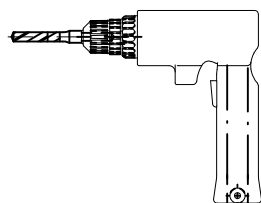

2 mm



4 mm



5 mm

Möglichkeiten der Systemkomponenten:
Options of system components:

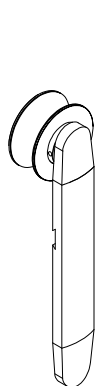

Rollenwagen TREND
Sliding door roller carrier TREND

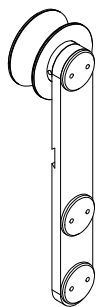

Rollenwagen CLASSIC
Sliding door roller carrier CLASSIC

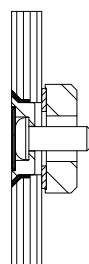

Punkthalter, versenkt
Countersunk single-point fixing

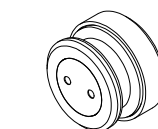
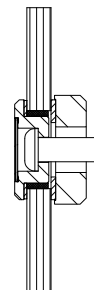

Punkthalter, aufliegend
Clamping disc single-point fixing

Montage Möglichkeiten:
Options of installation:

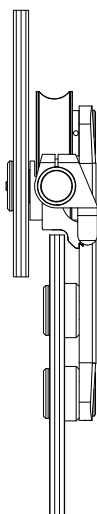

Montage Glas/Glas
Installation glass/glass

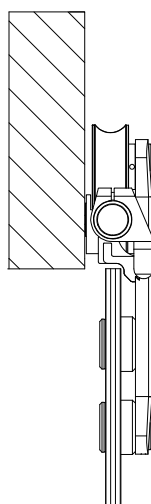

Montage Glas/Wand
Installation glass/wall

Lieferumfang:
Scope of delivery:

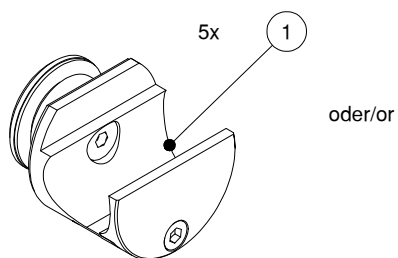

oder/or

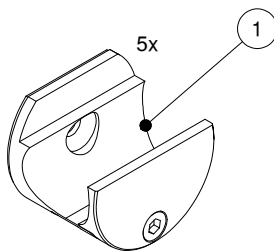

Klemmhalter an Glas, mit aufliegenden
oder versenkten Punkthalter

Klemmhalter an Wand
Clamp fixing onto wall

Clamp fixing to glass, with clamping
disc or countersunk fixing.

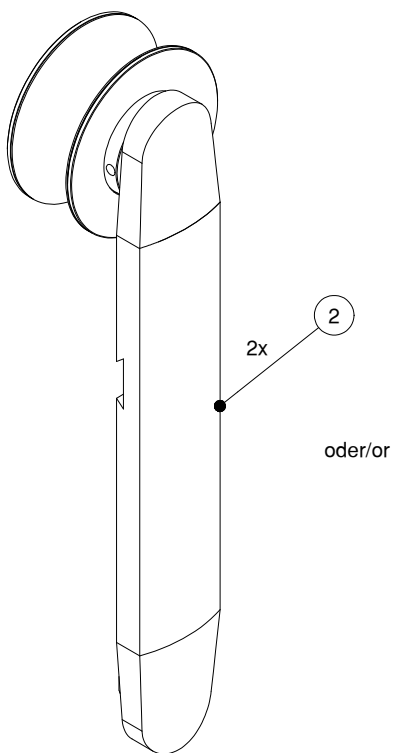

oder/or

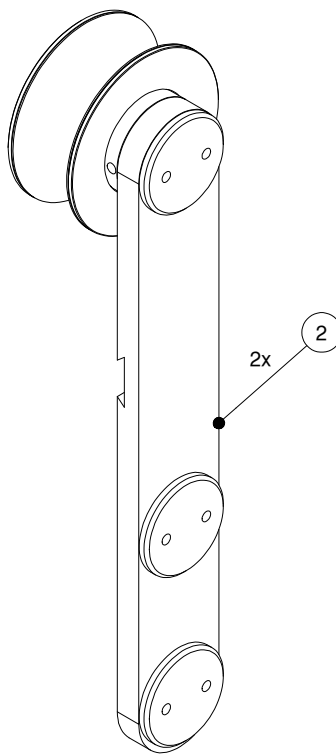

Rollenwagen TREND
Roller carrier TREND

Rollenwagen CLASSIC
Roller carrier CLASSIC

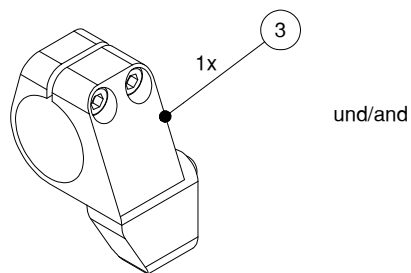

und/and

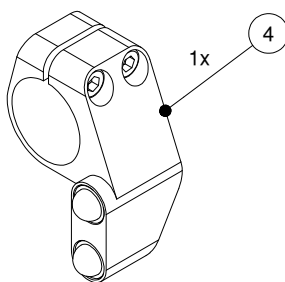

Türstopper links
door stop left hand

Türstopper rechts
door stop right hand

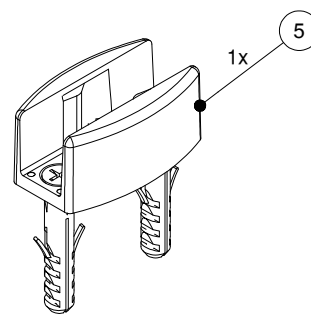

Bodenführung
floor guide

1. Vorbereitung Klemmhalter:
1. Preparation of clamp fixings:

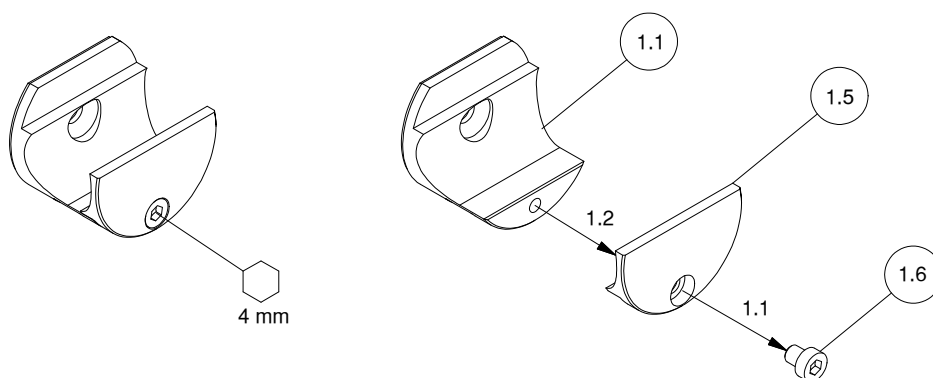

2. Montage an Wand:
2. Installation onto wall:

- 2.1 Abstandsempfehlungen (Technikhandbuch) beachten und Bohrungen zur Klemmhalterbefestigung anzeichnen.
 2.1 Please note the recommended distance (technical manual) of holes and mark the holes for the clamp fixing.

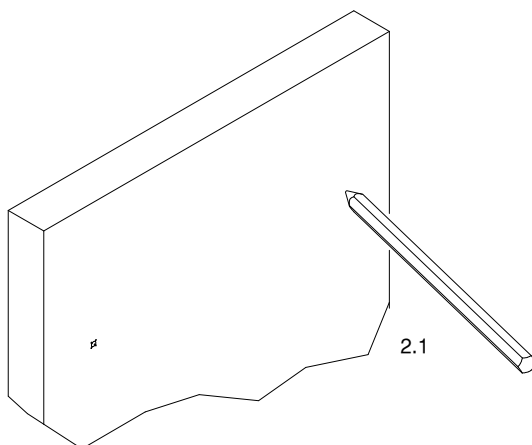

- 2.2 Befestigungslöcher bohren.
 2.2 Drill the attachment holes.

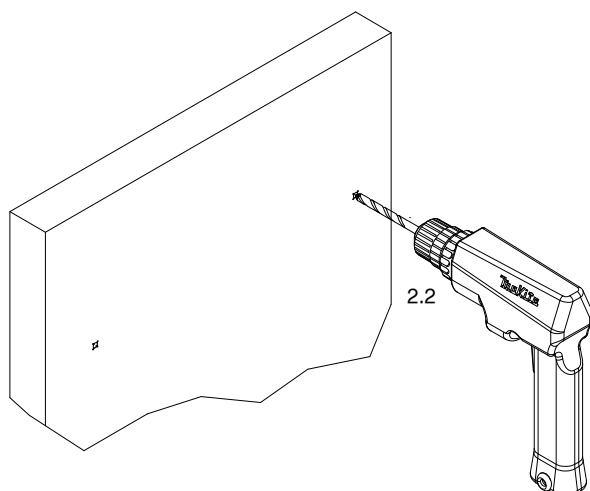

2.3 Montage Klemmhalter an Wand.
2.3 Installation of clamp fixing onto wall.

Schrauben und Dübel zur Wandbefestigung sind nicht im Lieferumfang enthalten! Befestigung je nach Wandbeschaffenheit bzw. Dübelart z.B. Senkschraube M6x... oder Senkholzschraube 6x...

Screws and plugs for wall connection are not part of delivery. Attachment according to wall state and kind of plug e.g. countersunk screw M6x... or countersunk wood screw 6x...

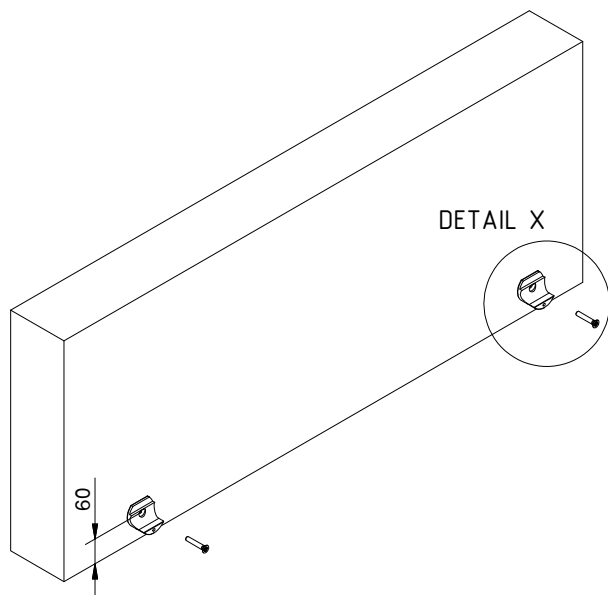

DETAIL X

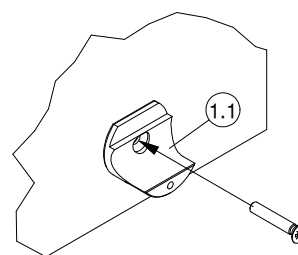

2.4 Montage Klemmhalter an Glas.
2.4 Installation of clamp fixing onto glass.

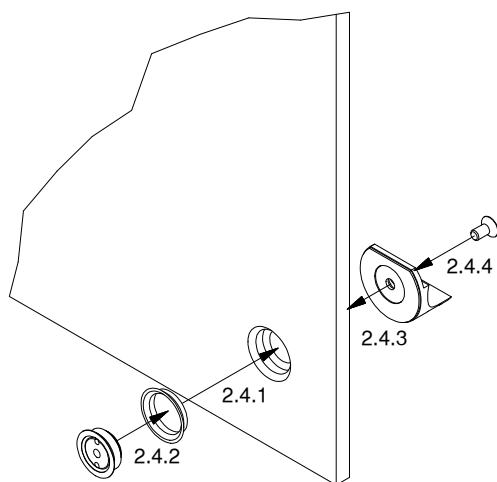

Klemmhalter mit versenkten Punkthalter an Glas.
Countersunk single-point fixing to glass.

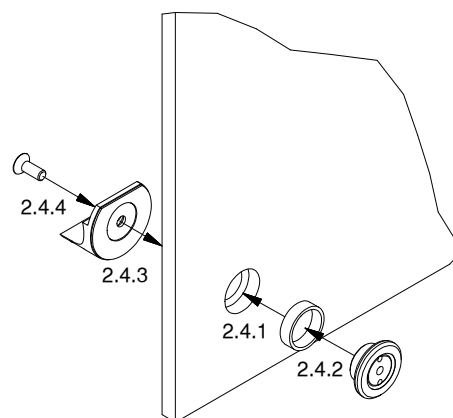

Klemmhalter mit aufliegenden Punkthalter an Glas.
Single-point fixing with clamping disc to glass.

**3. Montage des Laufschienenrohrs:
3. Installation of sliding track tube:**

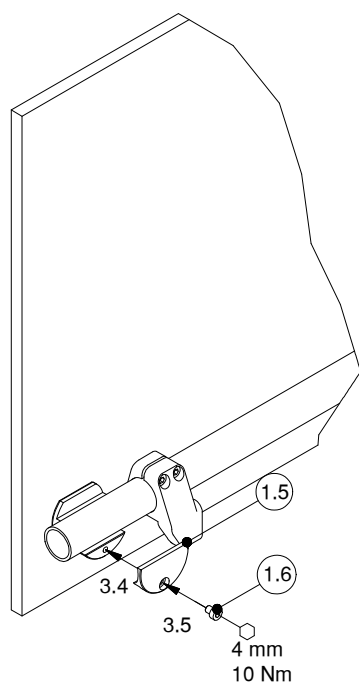
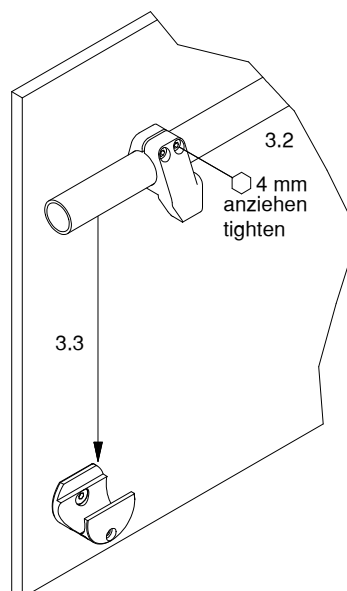
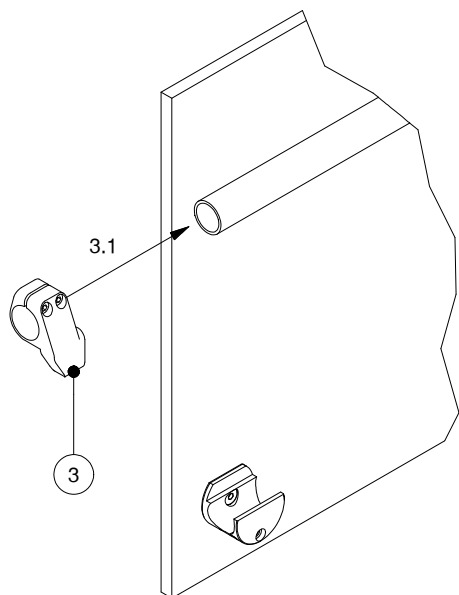

4. Montage Rollenwagen CLASSIC an Schiebetür.
4. Installation of roller carrier CLASSIC onto sliding door.

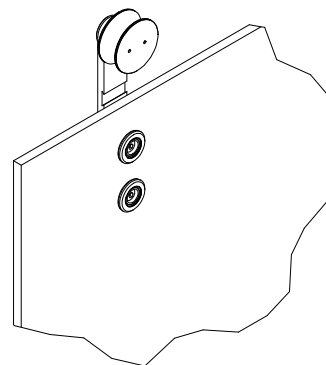
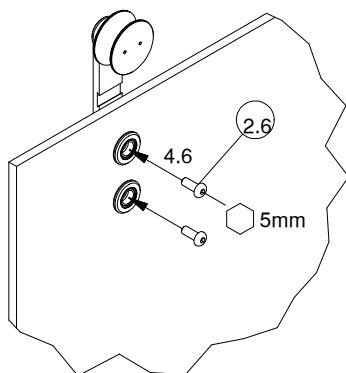
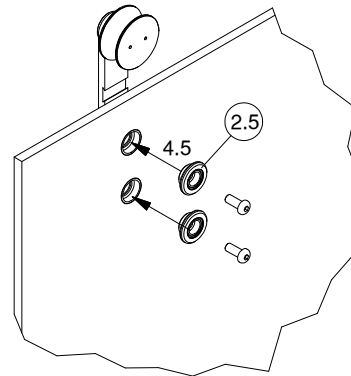
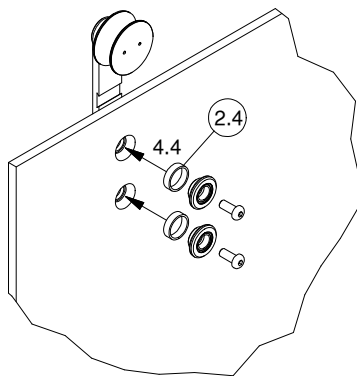
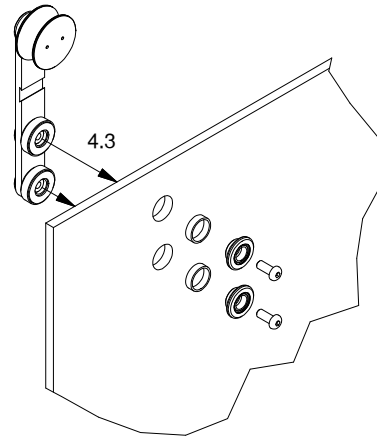
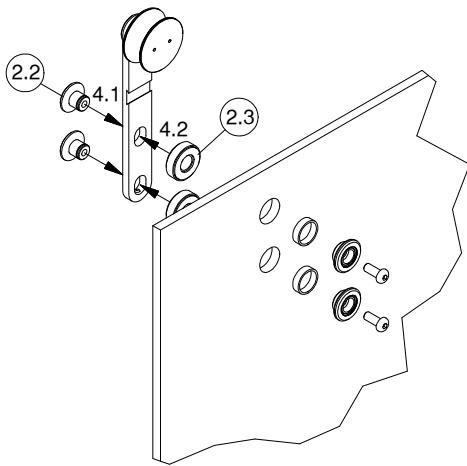

4. Montage Rollenwagen TREND an Schiebetür.
4. Installation of roller carrier TREND onto sliding door.

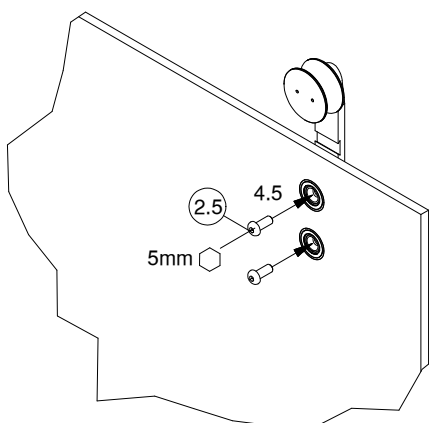
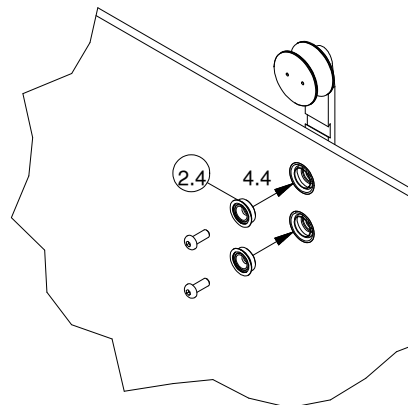
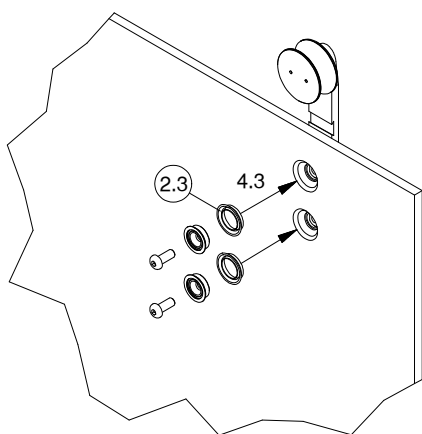
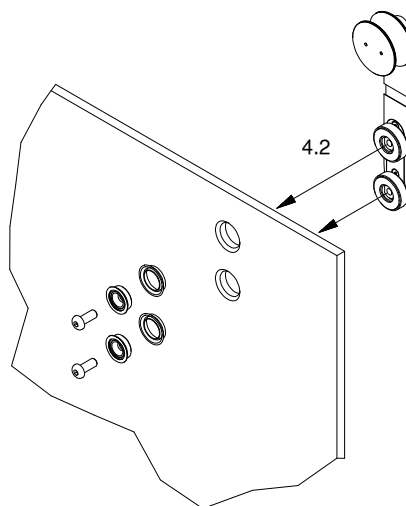
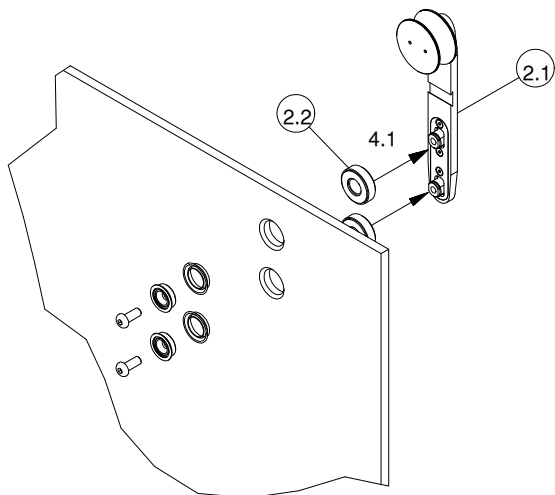

5. Montage der Bodenführung:
5. Installation of the floor guide:

5.1 Schiebetür einhängen. Bodenführung (5) einstellen, ausrichten und markieren.
 5.1 Fit sliding door. Adjust, set up and mark the floor guide (5) .

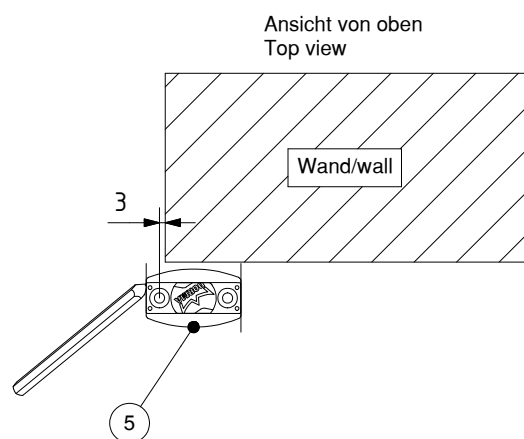
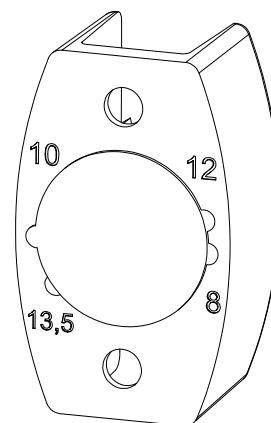
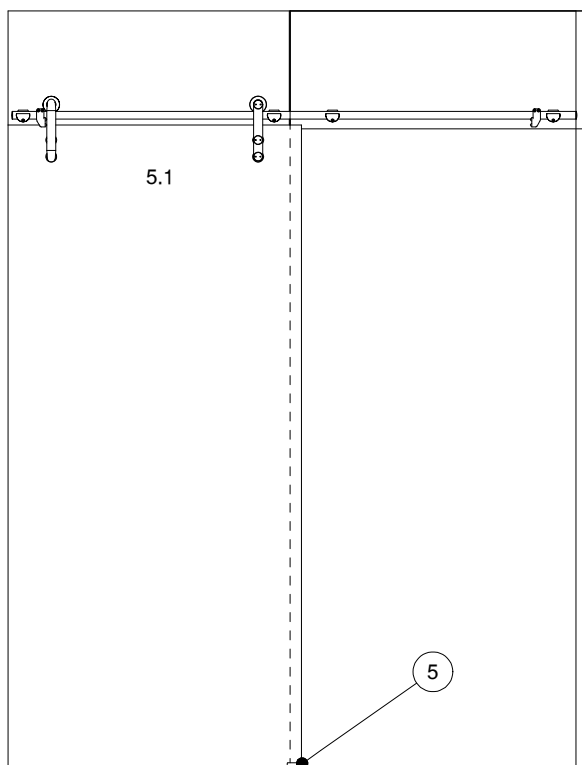

5.2 Schiebetür aushängen und Bohrungen markieren:
 5.2 Lift out sliding door and mark the holes:

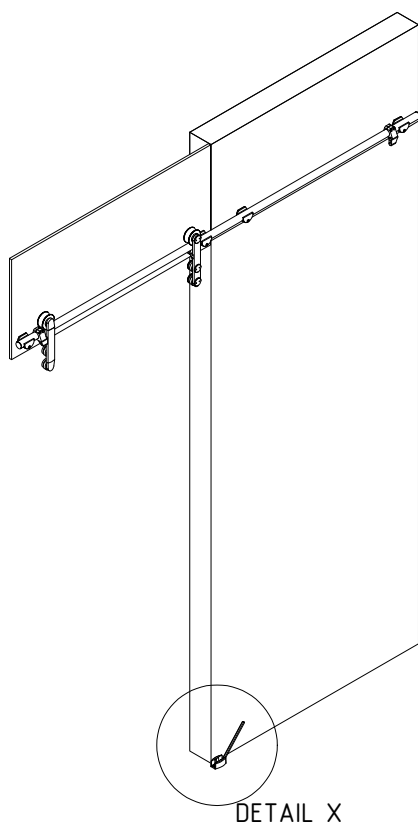

DETAIL X

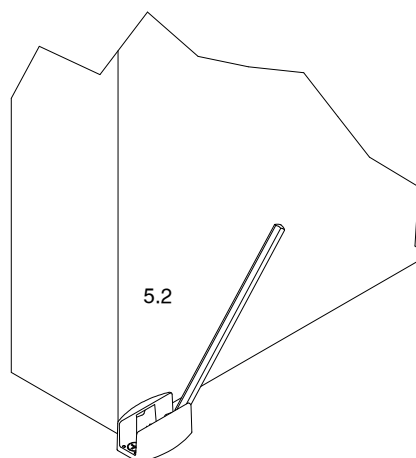

5. Montage der Bodenführung:
5. Installation of the floor guide:

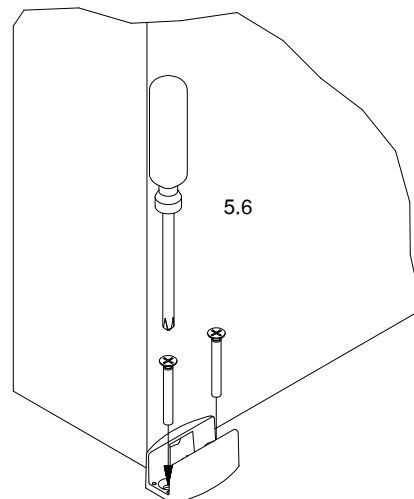
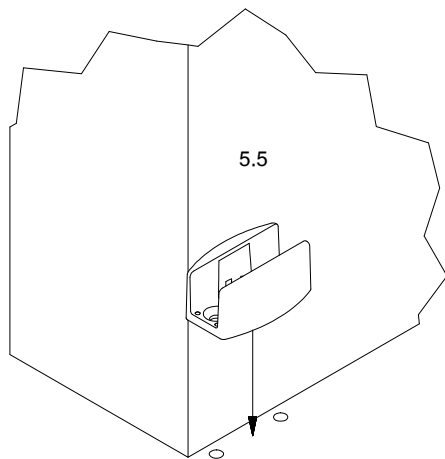
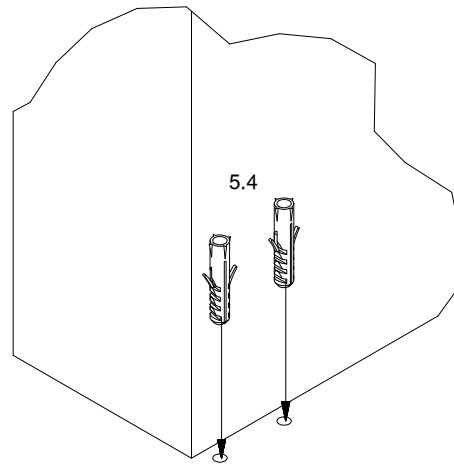
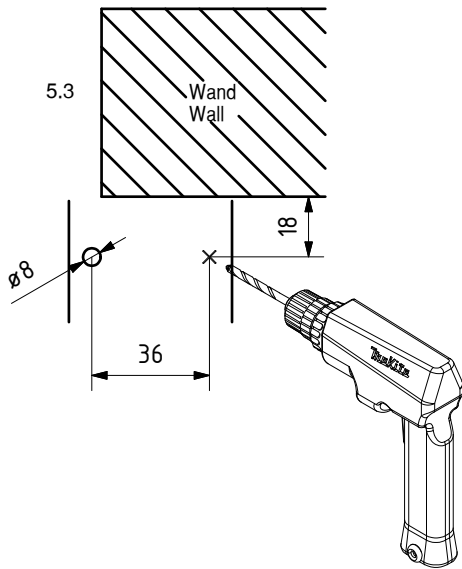

6. Montage Aushebeschutz:

6. Installation of the anti-jump device:

Universell einsetzbar für Rollenwagen TREND / CLASSIC
All purpose for roller carrier TREND / CLASSIC

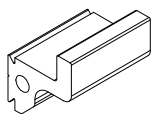

Aushebeschutz Klemmhalter
Anti-jump device for clamp fixing

6.1 Schiebetür einhängen

6.1 Fit sliding door

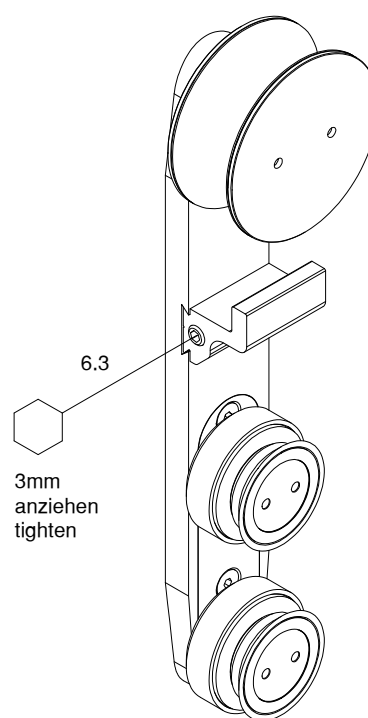
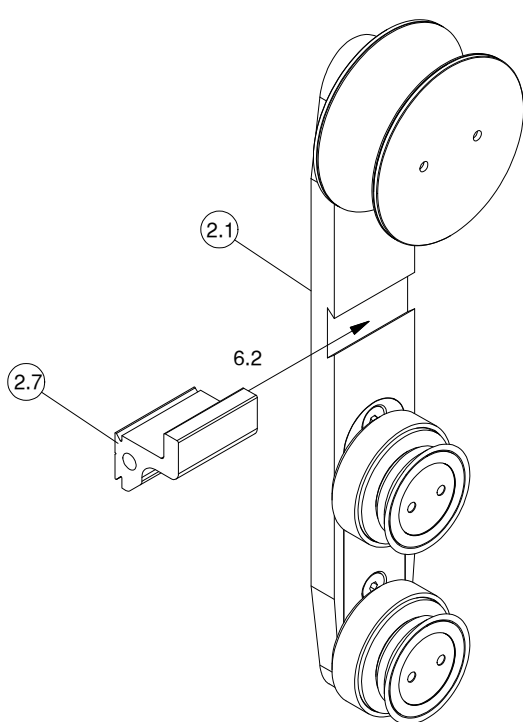

7. Schiebetüranlage ausrichten:
7. Adjustment of sliding door system:

7.1 Untere Glaskante auf Holz-/Kunststoffklötze abstützen (7mm Bodenluft).
 7.1 Support the lower glass edge onto timber/plastic blocks (7mm bottom air).

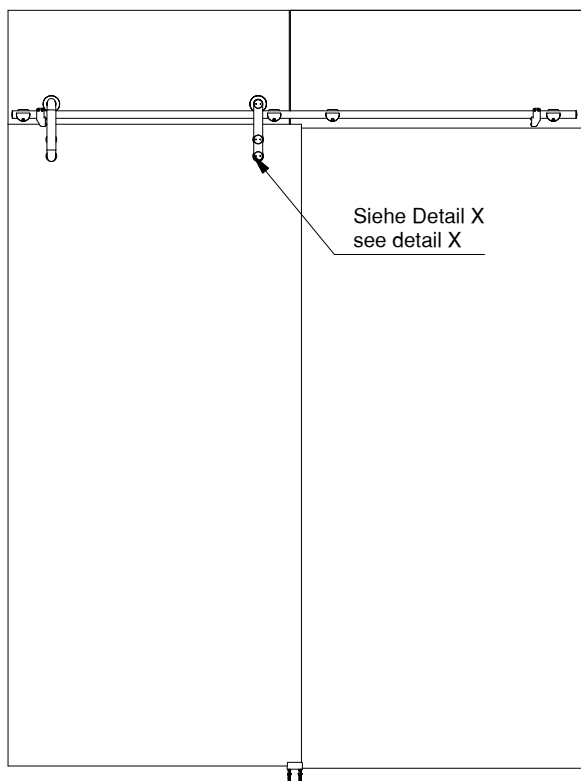

DETAIL X

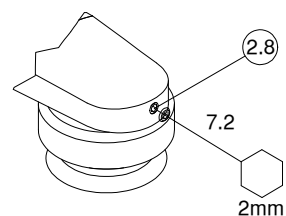

7.2 Justieren der Punkthalter mit Hilfe des Gewindestifts.
 7.2 Adjust the single-point fixing via the setscrew.

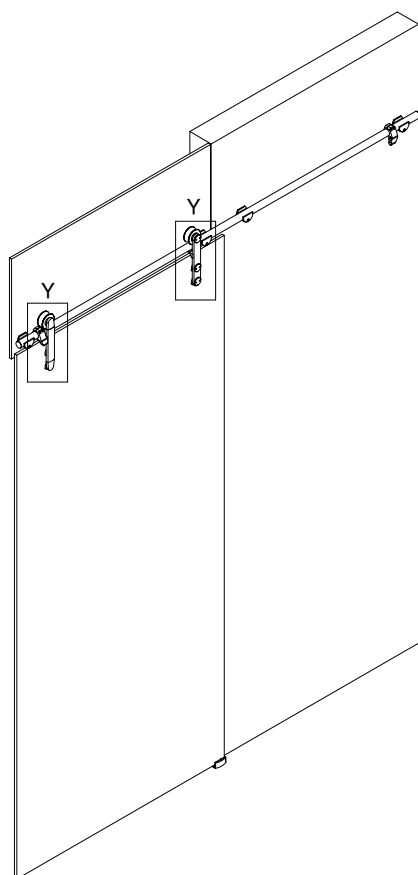

DETAIL Y

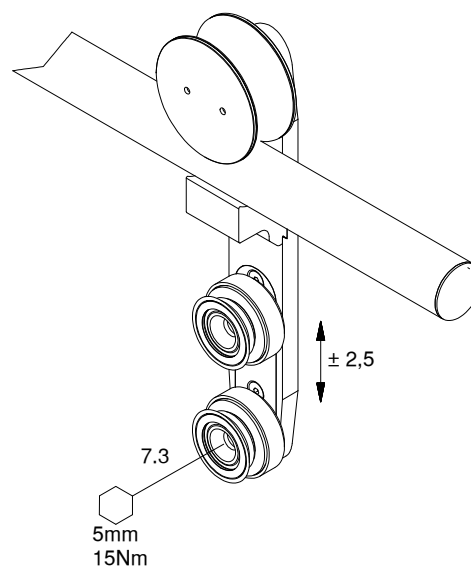

8. Deckel auf Punkt-/Klemmhalter montieren:
8. Installation of clip-on cover onto single-point fixing/clamp fixing:

 Abbildung Montage Punkthalter
 Illustration of installation by single-point fixing

Ausschnitt/ cut out

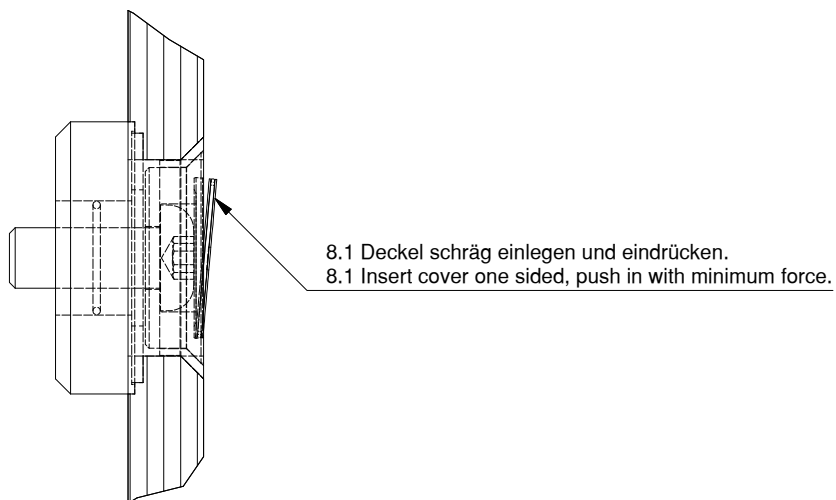

Ausschnitt/ cut out

